

Dimensions Part-turn actuators

With AUMA plug/socket connector and 3-phase AC motor

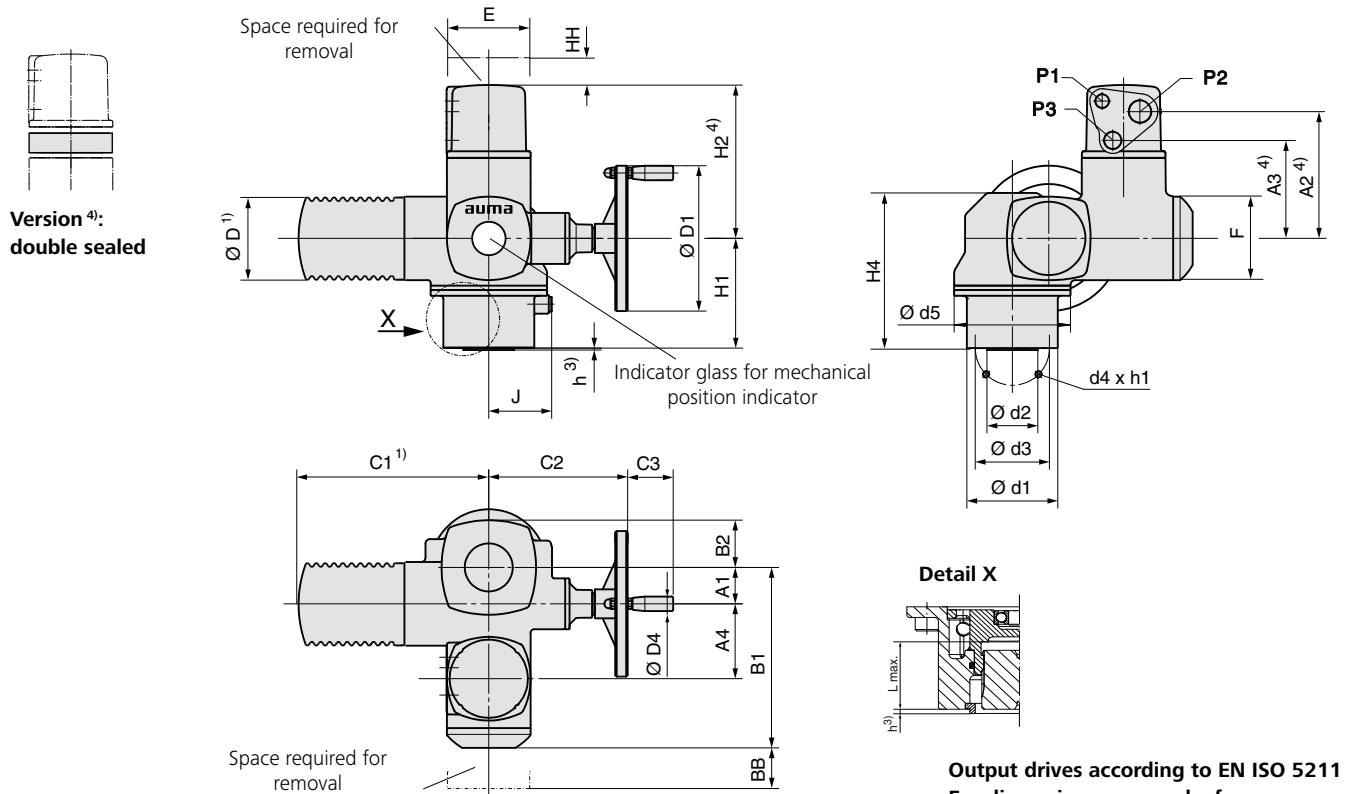

Output drives according to EN ISO 5211
For dimensions see overleaf

- 1) Exact dimension depending on motor used
- 2) Standard, other threads on request
- 3) Allowance for spigot is not available as standard. The spigot ring is a separate component, available as option.
- 4) Option: Enclosure protection IPxx-DS, cover for electrical connection with additional frame
- 5) Combined flange F05/F07 without spigot (standard). As an alternative an individual flange F07 can be ordered with spigot

Dimensions	SQ 05.2		SQ 07.2		SQ 10.2		SQ 12.2		SQ 14.2		
	EN ISO 5211	F05 ⁵⁾	F07 ⁵⁾	F05 ⁵⁾	F07 ⁵⁾	F10	F12	F12	F14	F14	F16
A1		40				50		50		50	
A2 ⁴⁾		174 (201 ⁴⁾)				174 (201 ⁴⁾)		174 (201 ⁴⁾)		174 (201 ⁴⁾)	
A3 ⁴⁾		134 (161 ⁴⁾)				134 (161 ⁴⁾)		134 (161 ⁴⁾)		134 (161 ⁴⁾)	
A4		103				103		103		103	
B1		238				248		248		248	
B2		50				65		65		65	
C1 ¹⁾		265				265		265		265	
C2		186				191		191		191	
C3		63				63		63		63	
Ø D ¹⁾		101				101		101		101	
Ø D1		160				200		200		200	
Ø D4		20				20		20		20	
E		115				115		115		115	
F		115				115		115		115	
H1		134		134	160	151	183	175	215	210	260
H2 ⁴⁾		210 (237 ⁴⁾)				210 (237 ⁴⁾)		210 (237 ⁴⁾)		210 (237 ⁴⁾)	
H4		193		193	217	214	246	238	278	273	323
J		69				86		109		128	
L max.		40		40	66	50	82	61	101	75	125
P1 ²⁾		M20 x 1.5				M20 x 1.5		M20 x 1.5		M20 x 1.5	
P2 ²⁾		M32 x 1.5				M32 x 1.5		M32 x 1.5		M32 x 1.5	
P3 ²⁾		M25 x 1.5				M25 x 1.5		M25 x 1.5		M25 x 1.5	
BB min.		180				180		180		180	
HH min.		30				30		30		30	
Ø d1		90		90	125	125	150	150	175	175	210
Ø d2		-		-	70	70	85	85	100	100	130
Ø d3		50	70	50	70	102	125	125	140	140	165
d4		4 x M6	4 x M8	4 x M6	4 x M8	4 x M10	4 x M12	4 x M12	4 x M16	4 x M16	4 x M20
Ø d5		125				160		210		225	
h ³⁾		-		-	2.5	2.5		2.5	3.5	3.5	4.5
h1		12	15	12	15	16	18	19	22	25	29

We reserve the right to alter data according to improvements made. Previous documents become invalid with the issue of this document.

Dimensions Couplings according to EN ISO 5211

Bore according to EN ISO 5211 with keyway according to DIN 6885-1

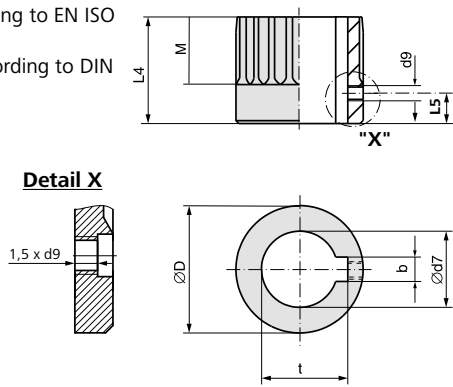

SQ../SQR..	05.2		07.2		10.2		12.2		14.2	
EN ISO 5211	F05	F07	F07	F10	F10	F12	F12	F14	F14	F16
Ø D	41.75	41.75	41.75	51.75	51.75	67.6	67.6	81.6	81.6	81.6
b JS9 ¹⁾	6	6	6	8	8	10	10	14	14	14
Ø d7 H8 ²⁾	18	22	22	28	28	36	36	48	48	48
Ø d7 max.	25.4	25.4	25.4	38	38	50	50	60	60	60
d9 ³⁾	M5	M5	M5	M6	M6	M6	M6	M6	M6	M6
L4	35	35	60	45	75	55	95	65	115	115
L5 ³⁾	8	8	8	10	10	10	10	10	10	10
M	20	20	20	30	30	40	40	47	47	40
t ¹⁾	20.8	24.8	24.8	31.3	31.3	39.3	39.3	51.8	51.8	51.8

Square bore according to EN ISO 5211

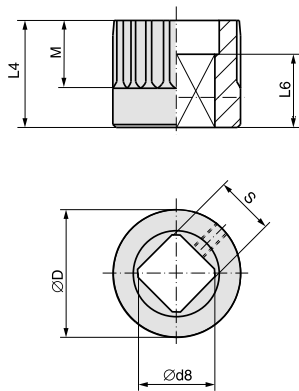

SQ../SQR..	05.2		07.2		10.2		12.2		14.2	
EN ISO 5211	F05	F07	F07	F10	F10	F12	F12	F14	F14	F16
Ø D	41.75	41.75	41.75	51.75	51.75	67.6	67.6	81.6	81.6	81.6
Ø d8 min. ²⁾	18.1	22.2	22.2	28.2	28.2	36.2	36.2	48.2	48.2	48.2
Ø d8 max.	28.2	28.2	28.2	40.2 ⁴⁾	40.2 ⁴⁾	48.2	48.2	60.2	60.2	60.2
L4	35	35	60	45	75	55	95	65	115	115
L6 min.	30	30	30	30	30	30	30	40	40	40
M	20	20	20	30	30	40	40	47	47	40
s H11 ²⁾	14	17	17	22	22	27	27	36	36	36
s H11 max.	22	22	22	30 ⁴⁾	30 ⁴⁾	36	36	46	46	46

Two-flat according to EN ISO 5211

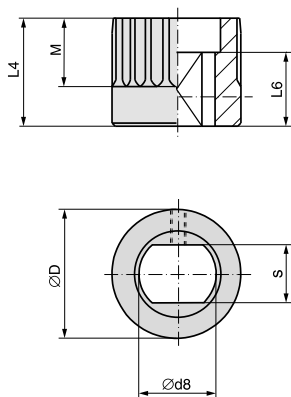

SQ../SQR..	05.2		07.2		10.2		12.2		14.2	
EN ISO 5211	F05	F07	F07	F10	F10	F12	F12	F14	F14	F16
Ø D	41.75	41.75	41.75	51.75	51.75	67.6	67.6	81.6	81.6	81.6
Ø d8 min. ²⁾	18.1	22.2	22.2	28.2	28.2	36.2	36.2	48.2	48.2	48.2
Ø d8 max.	28.2	28.2	28.2	36.2	36.2	48.2 (48 ⁵⁾)	48.2 (48 ⁵⁾)	60.2	60.2	60.2
L4	35	35	60	45	75	55	95	65	115	115
L6 min.	25	25	25	25	25	30	30	40	40	40
M	20	20	20	30	30	40	40	47	47	40
s H11 ²⁾	14	17	17	22	22	27	27	36	36	36
s H11 max.	22	22	22	27	27	36 (41 ⁵⁾)	36 (41 ⁵⁾)	46	46	46

Mounting position of the coupling within fitting dimensions according to AUMA definition

X max.	3	4	5	8
Y max.	2	5	10	10

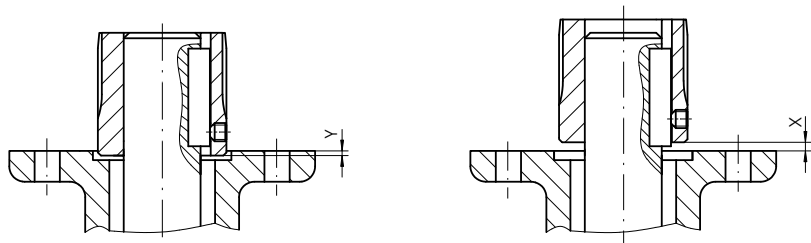

- 1) Dimensions depend on Ø d7, refer to DIN 6885-1
- 2) Recommended size according to EN ISO 5211
- 3) Thread with grub screw
- 4) According to DIN 79
- 5) According to DIN 475